

# BG24064D

## Feature

1. SMT PCB with metal frame
2. No built-in controller
3. 1/64 duty cycle
4. +5V power supply
5. built-in negative voltage
6. Option: temperature compensation
7. Option: LED array, EL B/L, CCFL



## Mechanical Data

Item	Standard Value	Unit
Module Dimension	180.0 x 65.0	mm
Viewing Area	133.0 x 39.0	mm
Dot Size	0.49 x 0.49	mm
Dot Pitch	0.53 x 0.53	mm

## Pin Assignment

Pin	Symbol	Function
1	FLM	First Line Marker
2	CP	Data Shift Clock
3	LP	Data Latch Clock
4	M	AC signal for LCD driver output
5	Vdd	Power supply (+5V)
6	Vss	Power supply (GND)
7	A	Backlight power supply(+)
8~11	DB0~DB3	Data bus line
12	Vo	Contrast adjustment
13	K	Backlight power supply(GND)
14	FGND	Frame GND

## Electronic Characteristics

Item	Symbol	Condition	Typical Value	Unit
Input Voltage	Vdd	Vdd = +5V	5.0	V
Supply Current	Idd	Vdd = +5V	40	mA
LCD Driving Voltage	Vo-Vss	25°C	2.5	V
LED Forward Voltage (yellow-green)	Vf	25°C	4.2	V
LED Forward Current	If	25°C	450	mA

## Dimension

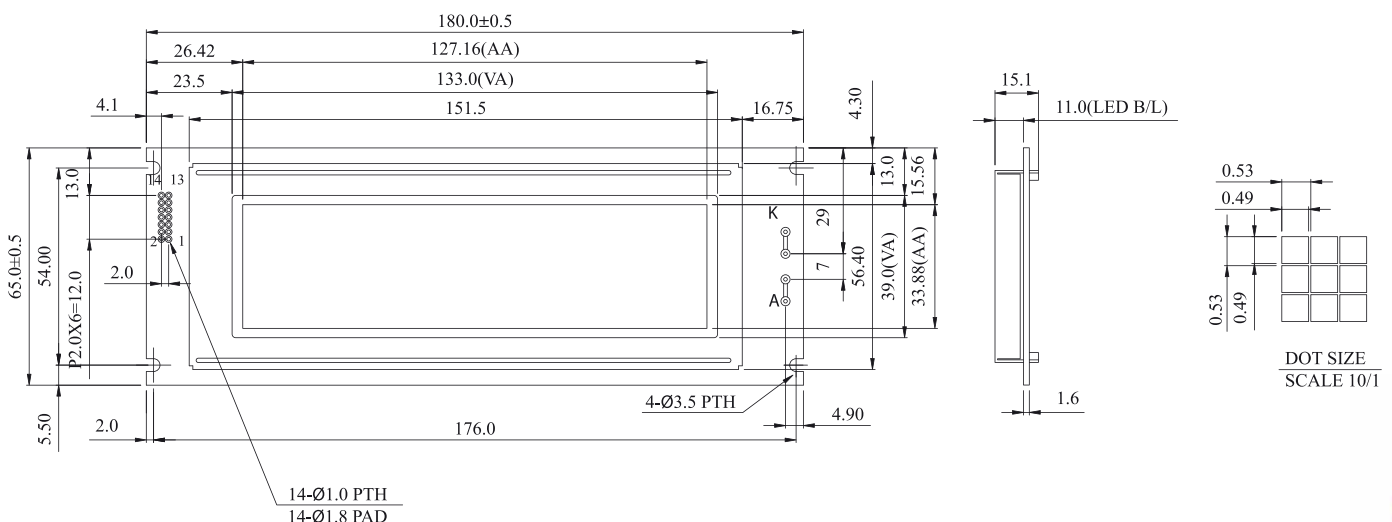

BG-42