

# Safety door switches with partially or full stainless steel body

# F3S-TGR-KM15/-KM16/-KH16

**This safety door switches use a stainless steel head or even a full stainless steel body to increase the robustness.**

- 2NC/1NO, 2NC/2NO or 3NC contacts
- Key entry turnable to back side
- 4 key insertion positions
- 3 M20 conduit entries
- Positive break contacts (to IEC 60947-5-1)



## Model Number Structure

### Switch

F3S-TGR-K<sub>1</sub><sub>2</sub><sub>3</sub>-□

- Housing Material:
  - M: Stainless steel head / Plastic body
  - H: Full stainless steel version
- Housing dimension:
  - 15: W 54 x L 88.4 x H 34.5 mm
  - 16: W 58 x L 100.4 x H 34.5 mm (Stainless steel head)  
W 58 x L 103.5 x H 39.5 mm (Full stainless steel version)
- Contacts:
  - 21: 2NC/1NO
  - 30: 3NC



### Operation Key

F39-TGR-K<sub>1</sub>

- Operation Key Type
  - AM: Standard key for metal head
  - F: Flat key for horizontal mounting
  - PF: Flexible key with plastic body
  - HF: Flexible key with die cast body
  - HFH: Flexible key with stainless steel body

## Ordering Information

### Switches





Type	Housing	Conduit	Contacts	Order code
	Plastic body with metal head	3 × M20	2NC/1NO Slow action	F3S-TGR-KM15-21
			3NC Slow action	F3S-TGR-KM15-30
	Plastic body with metal head		2NC/2NO Slow action	F3S-TGR-KM16-22
			3NC Slow action	F3S-TGR-KM16-30
	Full stainless steel body		2NC/2NO Slow action	F3S-TGR-KH16-22
			3NC Slow action	F3S-TGR-KH16-30

CONSULTING DISTRIBUTOR



POHL Electronic GmbH  
 Eduard-Maurer-Straße 11a • 16761 Hennigsdorf  
 Tel. +49 3302 81893-0 • Fax +49 3302 81893-99  
 www.pohl-electronic.de • info@pohl-electronic.de

**Keys (order separately)**

Type	Material	Order code
for metal head 	Stainless steel 316	F39-TGR-KAM
Horizontal mounting 	Stainless steel 316 (Plastic cover: Polyester)	F39-TGR-KF
plastic flexible 	Stainless steel 316 (Plastic housing: Polyester)	F39-TGR-KPF
heavy flexible 	Stainless steel 316 (Die-Cast metal housing)	F39-TGR-KHF <sup>*1</sup>
hygienic flexible 	Stainless steel 316	F39-TGR-KHFH

\*1. The key F39-TGR-KPF cannot be used with the guard-lock door switches (like F3S-TGR-KHL1/-KHL3/-KHL3R models)

**Accessories**

Item	Remarks	Order code
M20 Gland	Stainless steel 316 for F3S-TGR-KH16 types	F39-TGR-M20
Mounting screws	Set of Torx safety screws (M4, 4 × 30 mm, 4 × 20 mm, 4 × 10 mm; incl. washers and Torx bit)	F39-TGR-N-SCREWS

## Specifications

Item	F3S-TGR-KM15	F3S-TGR-KM16	F3S-TGR-KH16
<b>Standards</b>	ISO 14119, IEC 60947-5-1, EN 60204-1, UL508, EN ISO 13849-1: up to PLe <sup>1</sup> , EN 62061: up to SIL3*1		
<b>Reliability B10d</b>	2.5 × 10 <sup>6</sup> operations at 100mA load		
<b>Proof test interval (Life)</b>	35 years <sup>2</sup>		
<b>Utilization category</b>	AC15 A300 3 A		
<b>Thermal current (Ith)</b>	5 A		
<b>Rated insulation/Withstand voltages</b>	500 VAC/2,500 VAC		
<b>Rated travel for positive opening</b>	8 mm		
<b>Actuator entry minimum radius</b>	175 mm standard, 100 mm flexible		
<b>Maximum approach/Withdrawal speed</b>	600 mm/s		
<b>Body dimensions (W × H × D)</b>	54 × 88.4 × 34.5 mm	58 × 100.4 × 34.5 mm	58 × 103.5 × 39.5 mm
<b>Fixing</b>	2 × M5, 40 mm distance	4 × M5, 40 mm distance	
<b>Conduit entry</b>	M20		
<b>Material</b>	<b>Body</b>	Polyester	
	<b>Head</b>	Stainless steel 316	
<b>Enclosure Protection</b>	IP67		IP69K
<b>Temperature Range</b>	-25 to 80°C		
<b>Vibration</b>	IEC 68-2-6, 10-55 Hz +1 Hz, Excursion: 0.35 mm, 1 octave/min		

<sup>1</sup>: Depending upon system architecture

<sup>2</sup>: The safety functions and mechanics must be tested regularly. For applications where infrequent guard access is foreseeable, the system must have a manual function test to detect possible accumulation of faults. At least once per month for PLe Cat3/4 or once per year for PLd Cat3 (EN ISO 13849-1). Where possible it is recommended that the control system of the machine demands and monitors these tests and stops or prevents the machine from starting if the test is not done. (see ISO 14119)

**Note:** If used correctly with an OMRON safety control unit "G9SE/G9SA/G9SP" a single KM (KH) switch can achieve performance level PLc According to EN ISO 13849. To achieve PLe 2\* KM (KH) switches have to be used for same safety function. For more details on how to achieve a certain PL please refer to EN ISO 13849.

## Contact Form

Model	Contact	Contact form	Operating pattern												
F3S-TGR-K_-21	2NC/1NO		2NC 1NO      6.8 6.0    0 mm <table border="1"> <tr> <td>11/12</td> <td>Open</td> <td></td> </tr> <tr> <td>21/22</td> <td>Open</td> <td></td> </tr> <tr> <td>33/34</td> <td></td> <td>Open</td> </tr> </table>	11/12	Open		21/22	Open		33/34		Open			
11/12	Open														
21/22	Open														
33/34		Open													
F3S-TGR-K_-22	2NC/2NO		2NC 2NO      6.8 6.0    0 mm <table border="1"> <tr> <td>11/12</td> <td>Open</td> <td></td> </tr> <tr> <td>21/22</td> <td>Open</td> <td></td> </tr> <tr> <td>33/34</td> <td></td> <td>Open</td> </tr> <tr> <td>43/44</td> <td></td> <td>Open</td> </tr> </table>	11/12	Open		21/22	Open		33/34		Open	43/44		Open
11/12	Open														
21/22	Open														
33/34		Open													
43/44		Open													
F3S-TGR-K_-30	3NC		3NC      6.8 6.0    0 mm <table border="1"> <tr> <td>11/12</td> <td>Open</td> <td></td> </tr> <tr> <td>21/22</td> <td>Open</td> <td></td> </tr> <tr> <td>31/32</td> <td>Open</td> <td></td> </tr> </table>	11/12	Open		21/22	Open		31/32	Open				
11/12	Open														
21/22	Open														
31/32	Open														

## Dimensions

Tolerance class IT16 applies to dimensions in this data sheet unless otherwise specified.

### Switches

#### F3S-TGR-KM15

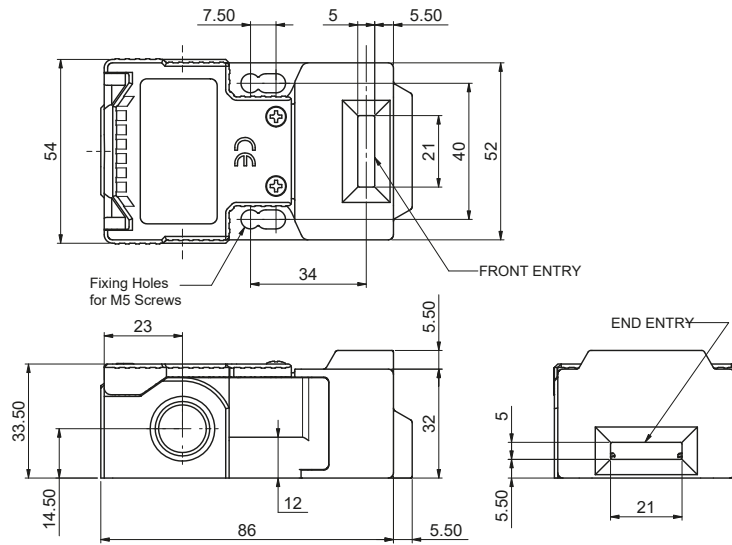

#### F3S-TGR-KM16

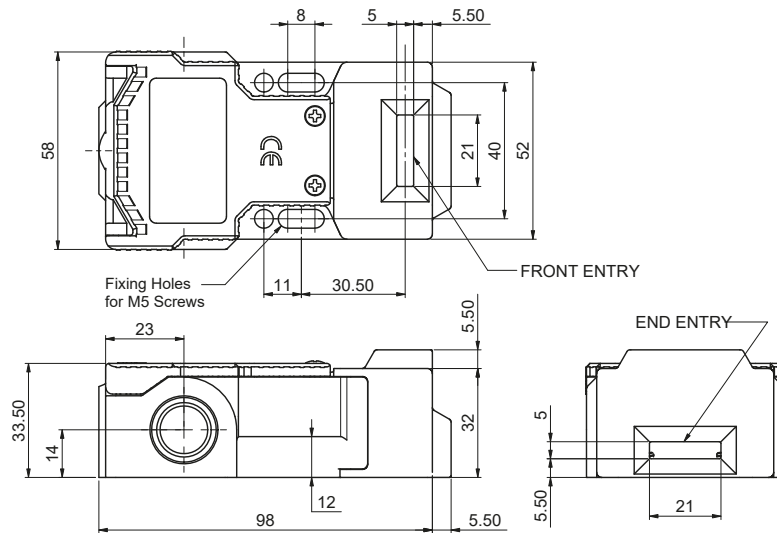

#### F3S-TGR-KH16

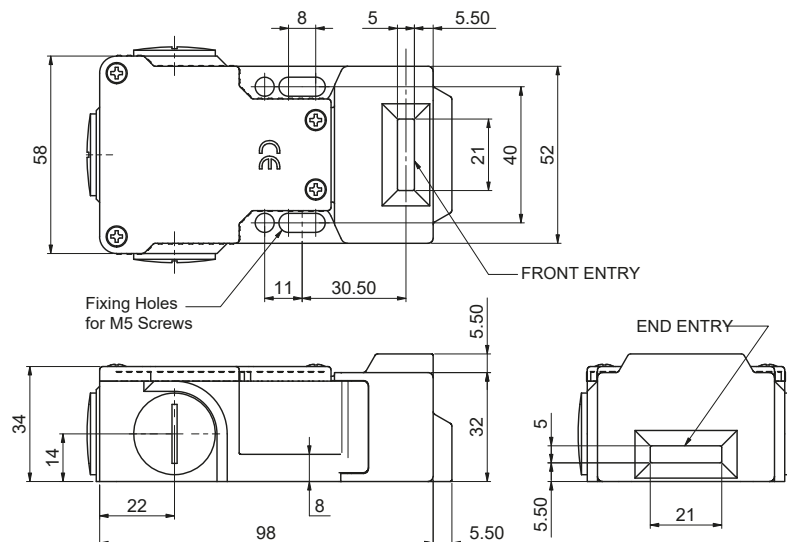

## Operation Keys

### F39-TGR-KAM

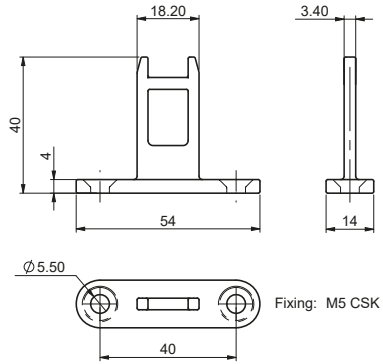

### F39-TGR-KF

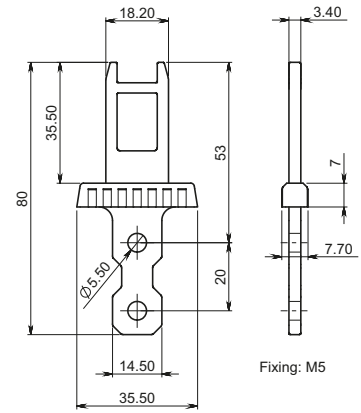

### F39-TGR-KPF

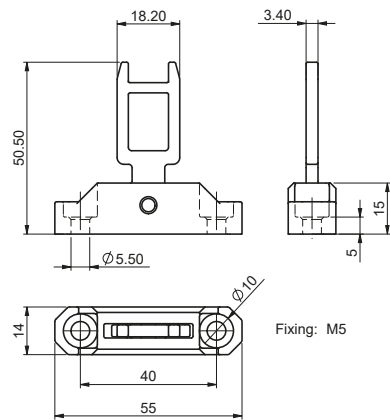

### F39-TGR-KHF F39-TGR-KHFH

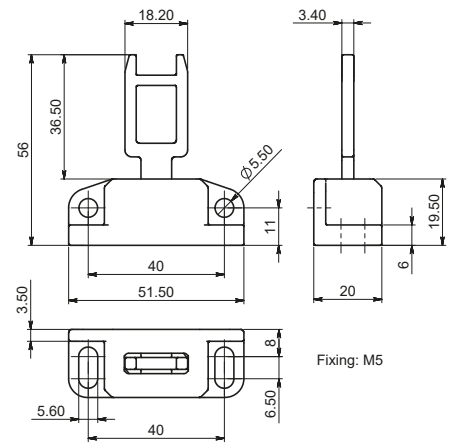

## Safety Precautions

### CAUTION

Do not dismount the operation key from the door intentionally and insert it to the switch with the door open. Machine may start operating and injury or death may be caused.

Do not use metal connector or conduit with switch type F3S-TGR-KM, only for F3S-TGR-KH. The broken conduit hole may cause electrical shock hazard.

#### Precautions for Safe Use

- Be careful not to drop your safety door switch, or it will not fully exhibit its ability.
- Do not disassemble or remodel your safety door switch in any case, or the switch will not operate normally.
- Do not use the switch where explosive gas, ignitable gas, or any other harmful gasses may be present.
- Install operation key so that it will not hit the operator when the door is open. Injury may be caused.
- Do not use the switch with IP67 in the oil and in the water. IP67(EN60947-5-1)
- Though the switch body is protected from the ingress of dust or water, avoid the ingress of foreign substance through the key hole on the head. Otherwise, wear in short time or break may be caused
- Do not put the electric power when wiring.
- Be sure to install a cover after the wiring. Do not put the electric power when opening a cover.
- Connect the fuse to the switch in series to prevent it from short circuit damage. The value of the breaking current of the fuse must be increased to cover the rated current by 150 to 200%. When using the switch with EN rating, use 10 A fuse, type gl or gG that complies with IEC 60269.
- Keep the electrical load below the rated value.
- On the switching of general loads (250VAC/3A), do not operate two circuits or more at the same time. Otherwise, insulation performance may be degraded.
- The durability of the switch is seriously affected by operating conditions. Evaluate the switch under actual working conditions before permanent installation.
- Please mention in machine manufacturer's Instruction. Manual that the user must not repair nor maintain the switch and must contact machine manufacturer for them.
- Do not use the switch as a stopper. Be sure to install a stopper as shown in the following illustration to prevent the edge of the operation key from inadvertently hitting the switch directly.

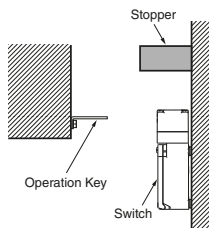

- The Risk Assessment for the particular application should include the risk of spare actuators. Spare actuators should not be readily available and must be securely controlled. (ISO14119)

#### Precautions for Correct Use

##### 1. Environment

- The switch is intended for indoor use only.
- Do not use your switch outdoor, or the switch will malfunction.
- Do not use your switch in the atmosphere of hazardous gases (H<sub>2</sub>S, SO<sub>2</sub>, NH<sub>3</sub>, HNO<sub>3</sub>, Cl<sub>2</sub>, etc.) or high temperature and humidity, or it will cause the imperfect closing of the contacts or the breakage thereof stemming from corrosion.
- Do not use the switch under any of the conditions mentioned below.
  - Frequent temperature range.
  - High humidity or dew condensation may be generated.
  - Where the switch is subject to severe vibration.
  - Where the metal dust, oil, or chemical is sprayed inside the door.
  - Where thinner is applied.

##### 2. Mounting method

- Mounting Screw Tightening Torque (4 Nm)  
Loose mounting may result in malfunction. Fasten the screws to the specified torque.
- Switch, operation key
  - The switch and operation key will be fastened to specified torque in item 2 with M4 screws and washers.
  - Do not use the operation key other than dedicated OMRON's. Otherwise switch may be damaged.
  - Be sure that the operation key can be inserted properly to key hole with a tolerance of ± 1 mm.

##### 3. Head direction

The rotation of the switch head may be adjusted to any of the four directions by loosening the head clamping screws at the four corners of the head.

##### 4. Securing of the door

If the operation key is pulled in the opening direction due to a force caused by vibration, by the door weight, or by a cushion attached to the door.

The closed door must be secured with a hook or by similar means.

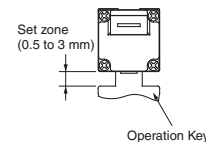

##### 5. Wiring

- When connect with insulation tubes and terminals, connect the terminals as shown in the following figure and wire without overriding to the case and the cover. Adequate conductor size is AWG 20 to 18 (0.5 to 0.75 mm<sup>2</sup>).
- Do not push the ring connector and the likes into the opening between the parts in order to prevent the case from being broken and deformed.
- Use terminals having the thickness of 0.5 mm or less to avoid the contact between the terminal and the switch case inside.

##### 6. Conduit opening

Use the connectors recommended in clause 7 and tighten the connector with specified torque in clause 2. An excessive torque will bring a case breakage.

Apply sealing tape between connector and conduit opening so that the enclosure will conform to IP67.

Use a cable with a suitable diameter for the connector.

For unused conduit opening, apply a conduit cap provided and tighten it to specified torque in clause 2.

## 7. Recommendation of connector

Use the connector with thread section of 9 mm long or less. In the case of the connector with longer thread section, protruded part may interfere with the other parts inside the body. Use below listed connector to secure IP67.

Size connector	Manufacturer	Type	Adequate cable Diameter
M20	LAPP	ST-M20 × 1.5 5311-1020	7.0 to 13.0 mm

When use LAPP's products, use together with a seal packing which is sold separately (Type name GPM20.) and tighten with proper tightening torque.

LAPP is a German manufacturer.

## 8. Storage

Do not keep the switch in dusty, humid place and any place where gas may be present for example H<sub>2</sub>S, SO<sub>2</sub>, NH<sub>3</sub>, HNO<sub>3</sub>, Cl<sub>2</sub>.

## 9. Others

- Do not impose excessive force on the key top while the operation key is inserted into the switch body or drop the switch with the operation key inserted to avoid the deformation of the key or the breakage of the switch body.
  - Confirm that the seal rubber has no abnormality and then use it. If the seal rubber is displaced or floated, or if foreign matters adhere to the seal rubber, the seal rubber will lose its sealing capability.
  - Do not use any screw other than correct one, or the sealing capability of the seal rubber will deteriorate.
- Please do a regular check in premeditation for this switch.



Cat. No. F21E-EN-01B

In the interest of product improvement, specifications are subject to change without notice.

---

## OMRON EUROPE B.V.

Wegalaan 67-69,  
NL-2132 JD, Hoofddorp,  
The Netherlands  
Phone: +31 23 568 13 00  
Fax: +31 23 568 13 88  
industrial.omron.eu