

Solid State Relays with Built-in Current Transformer

G3PF

Built-in CT: A New Concept in SSRs!

The SSR can now detect heater burnout and SSR short-circuit failure.

Heater Burnout
Detection
SSR Short-circuit
Detection

Reduced
Wiring

Easy
Setting



Built-in CT

Note:
The photo is a
conceptualization.

CONSULTING DISTRIBUTOR



POHL Electronic GmbH
Eduard-Maurer-Straße 11a • 16761 Hennigsdorf
Tel. +49 3302 81893-0 • Fax +49 3302 81893-99
www.pohl-electronic.de • info@pohl-electronic.de

Available with any of 3 input terminal types.



M3 Terminals

Removable Screwless
Clamp Terminals

Removable Small
Slot Terminals

realizing

Features



1

Heater Burnout Detection

- The built-in CT monitors the load current.
- Burnout can be detected for 1-line heaters or for 1 line in multiple heaters.
- Detection is also possible for 3-phase heater circuits.

Example: Burnout Detection for One Line in Multiple Heaters

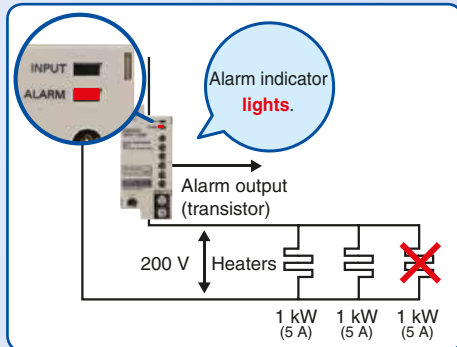

Normal current: 15 A (5 A × 3 lines)
 Current with one heater burnt out: 10 A (5 A × 2 lines)
 Recommended burnout detection setting:
 13 A (midway between 10 and 15 A)

Example: Burnout Detection for a Three-phase Heater

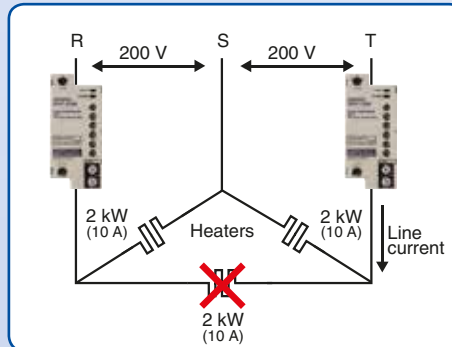

Normal current: 17.3 A ($10 \text{ A} \times \sqrt{3}$)
 Current with one heater burnt out: 10 A ($10 \text{ A} \times \sqrt{3} \times \frac{1}{\sqrt{3}}$)
 Recommended burnout detection setting:
 14 A (midway between 10 and 17.3 A)

2

SSR Short-circuit Failure Detection

- The built-in CT can detect SSR short-circuit failures.
- The alarm indicator shows if a heater burnout or SSR short-circuit failure has occurred.
- Separate alarm outputs are provided on models with screwless clamp terminals or small slot terminals.

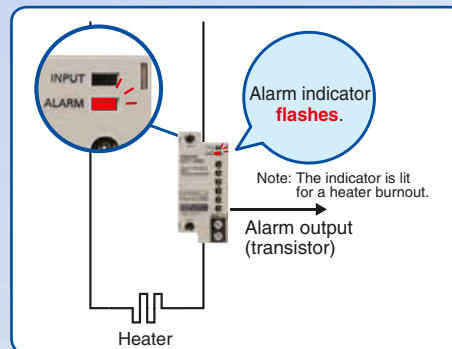

3

Easy Setting of Heater Burnout Detection Level

- The decimal rotary switches can be used to easily set the heater burnout detection level.
- The setting switches are provided on the front panel to enable easy confirmation of the setting.

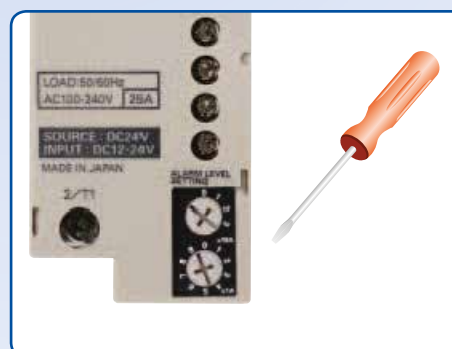

Save Space and Reduce Work Steps

The CT is built into the SSR, so no space is required for CT installation and wiring work is reduced.

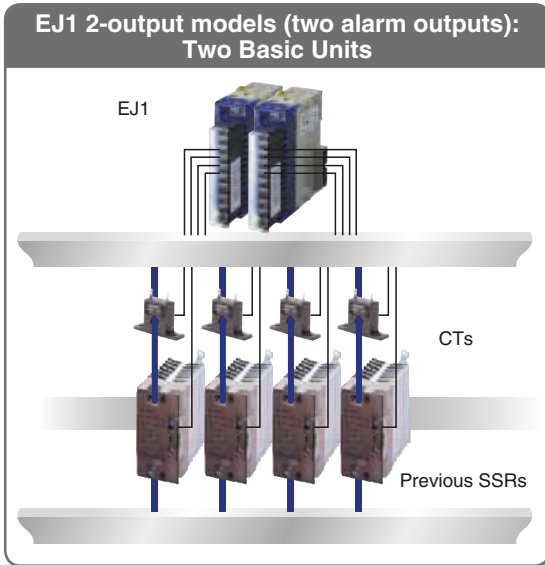

When detecting heater burnouts with OMRON's EJ1 Modular Temperature Controller, each Controller provides two outputs, so two Controllers are required to control four SSRs.

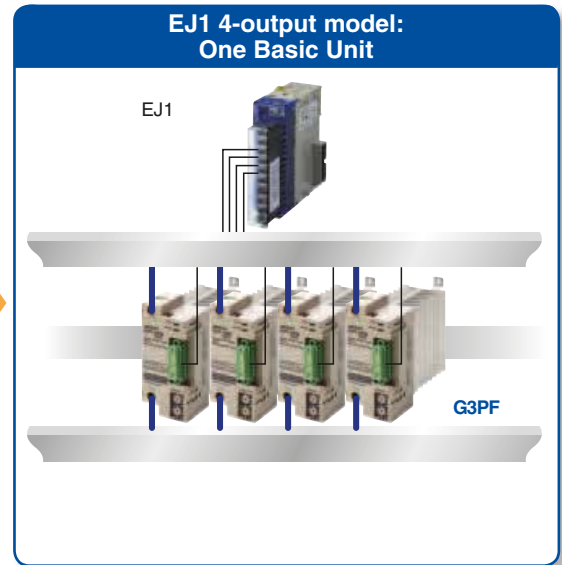

Using the G3PF for heater burnout detection allows an EJ1 Basic Unit with four outputs to be used. This lowers the cost per output and helps reduce the space required for installation on the control panel.

Note: When using the EJ1, an End Unit is required in addition to the Basic Units.

A New Proposal for Heater Burnout Detection: SSR with Built-in CT

Wide Range of Applications

The G3PF quickly detects heater burnout and SSR short-circuit failure, and information is provided to let you know which problem has occurred, which is ideal for applications where down time must be minimized.

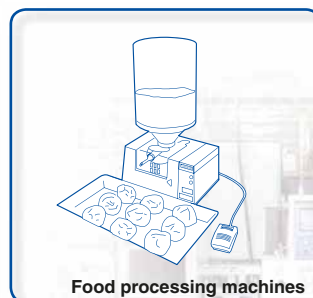
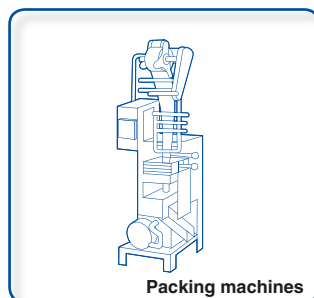
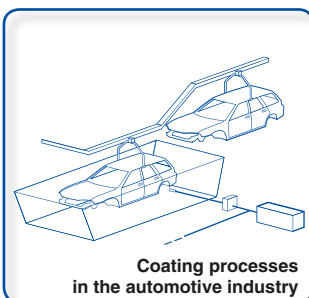
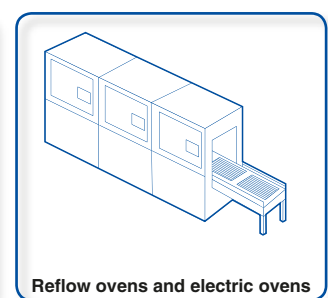
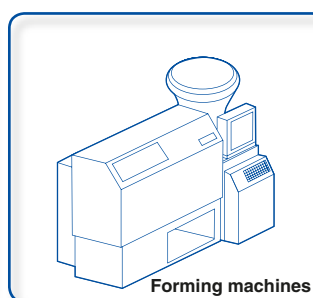
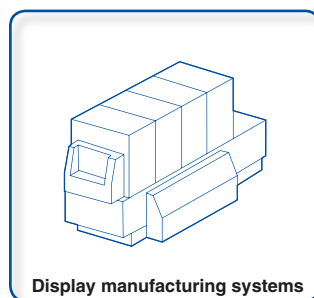
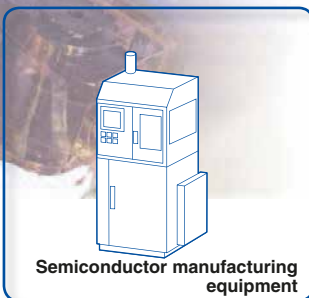

And many other applications.

Solid State Relays with Built-in Current Transformer

G3PF

A New-concept SSR with Built-in Current Transformer.

Heater Burnout and SSR Short-circuit Failure Detection.

- Built-in Current Transformer (CT) helps reduce wiring steps.
- Detects the burnout of any one of a group of heaters.
- Detects the burnout of 3-phase heaters.
- Detects SSR short-circuit failures.
- Error detection level can be easily set with a switch.
- Mounts to a DIN track or with screws.
- Three types of input terminals available: M3 terminals, screwless clamp terminals (detachable), or compact slotted screw terminals (detachable).
- Applications have been submitted for UL, CSA, and EN certification.



Ordering Information

List of Models

Input terminals	Isolation method	Zero cross function	Operation indicator	Alarm output	Applicable load (See note.)	Model
M3 terminals	Phototriac-coupler	Yes	Yes	1 output	2 to 25 A, 100 to 240 VAC	G3PF-225B
Screwless clamp terminals (detachable)					2 to 35 A, 100 to 240 VAC	G3PF-235B
					2 to 25 A, 200 to 480 VAC	G3PF-525B
					2 to 35 A, 200 to 480 VAC	G3PF-535B
				2 outputs (Heater Burnout Detection, SSR Short-circuit Failure Detection)	2 to 25 A, 100 to 240 VAC	G3PF-225B-CTB
					2 to 35 A, 100 to 240 VAC	G3PF-235B-CTB
					2 to 25 A, 200 to 480 VAC	G3PF-525B-CTB
					2 to 35 A, 200 to 480 VAC	G3PF-535B-CTB
				Compact slotted screw terminals (detachable)	2 outputs (Heater Burnout Detection, SSR Short-circuit Failure Detection)	2 to 25 A, 100 to 240 VAC
2 to 35 A, 100 to 240 VAC						G3PF-235B-STB
2 to 25 A, 200 to 480 VAC						G3PF-525B-STB
2 to 35 A, 200 to 480 VAC						G3PF-535B-STB

Note: The load current depends on the ambient temperature. Refer to *Load Current vs. Ambient Temperature* under *Engineering Data* for details.

Specifications

Certification

UL 508 (application submitted), CSA 22.2 No. 14 (application submitted), EN 60947-4-3 (application submitted)

Ratings

Detection Power Supply

Rated power supply voltage	24 VDC
Operating voltage range	20.4 to 26.4 VDC
Current consumption	50 mA DC max. (at 24 VDC)

Alarm Output

Output OFF collector voltage	30 VDC max.
Maximum carry current	100 mA
Output form	NPN open collector (ON when error is detected.)
Minimum load current	0.1 mA

Operation Input

Input method	Voltage input
Rated input voltage	12 to 24 VDC
Operating input voltage range	9.6 to 26.4 VDC
Operate voltage	9.6 VDC max.
Release voltage	1.0 VDC min.
Input current	5 mA DC max. (at 12 VDC) 10 mA DC max. (at 24 VDC)

● Main Circuit

Item	Model		G3PF-225B	G3PF-235B	G3PF-525B	G3PF-535B
			G3PF-225B-CTB	G3PF-235B-CTB	G3PF-525B-CTB	G3PF-535B-CTB
			G3PF-225B-STB	G3PF-235B-STB	G3PF-525B-STB	G3PF-535B-STB
Rated load voltage	100 to 240 VAC (50/60 Hz)			200 to 480 VAC (50/60 Hz)		
Operating voltage range	75 to 264 VAC, 50/60 Hz			180 to 528 VAC, 50/60 Hz		
Applicable load current*	25 A (at 40°C)		35 A (at 40°C)		25 A (at 40°C)	
Minimum load current	2 A					
Inrush current resistance	220 A (60 Hz, 1 cycle)		430 A (60 Hz, 1 cycle)		220 A (60 Hz, 1 cycle)	

Note: The load current depends on the ambient temperature. Refer to *Load Current vs. Ambient Temperature* under *Engineering Data* for details.

■ Characteristics

Item	Model		G3PF-225B	G3PF-235B	G3PF-525B	G3PF-535B
			G3PF-225B-CTB	G3PF-235B-CTB	G3PF-525B-CTB	G3PF-535B-CTB
			G3PF-225B-STB	G3PF-235B-STB	G3PF-525B-STB	G3PF-535B-STB
Operate time	1/2 of load power source cycle + 1 ms max.					
Release time	1/2 of load power source cycle + 1 ms max.					
Main circuit	Output ON voltage drop	1.6 V (RMS) max.			1.8 V (RMS) max.	
	Leakage current	10 mA max. (at 200 VAC)			20 mA max. (at 480 VAC)	
Alarm output	Output ON voltage drop	1.5 V max.				
	Leakage current	1 mA max.				
Isolation resistance	100 MΩ min. (at 500 VDC)					
Dielectric strength	2,500 VAC, 50/60 Hz for 1 min.					
Vibration resistance	Destruction: 10 to 55 to 10 Hz, 0.35-mm single amplitude (0.7-mm double amplitude)					
Shock resistance	Destruction: 294 m/s ²					
Ambient storage temperature	-30 to 70°C (with no icing or condensation)					
Ambient operating temperature	-20 to 60°C (with no icing or condensation)					
Ambient operating humidity	45% to 85%					
Weight	Approx. 400 g		Approx. 630 g		Approx. 400 g	

Connection

■ Connection Example

G3PF-□□□B

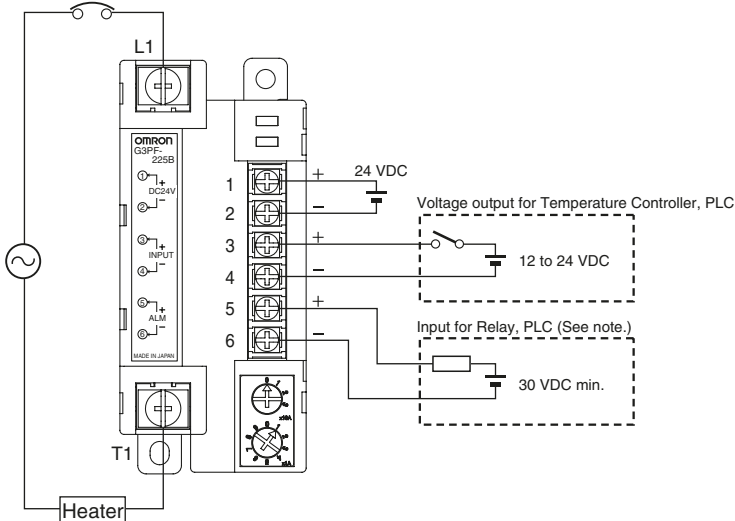

Note: With inductive loads (relay coil, etc.), connect back-current prevention diodes to both sides of the load.

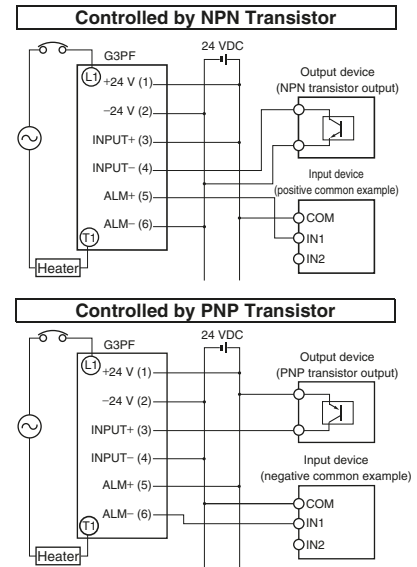

Solid State Relays with Built-in Current Transformer G3PF

G3PF-□□□B-CTB, G3PF-□□□B-STB

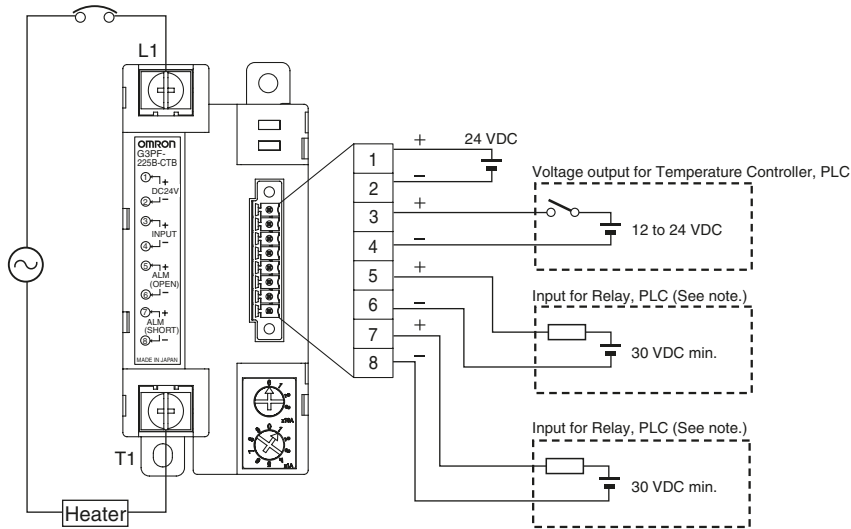

Note: With inductive loads (relay coil, etc.), connect back-current prevention diodes to both sides of the load. Terminals 5-6 output a heater burnout alarm, and terminals 7-8 output an SSR short-circuit failure alarm.

Controlled by NPN Transistor

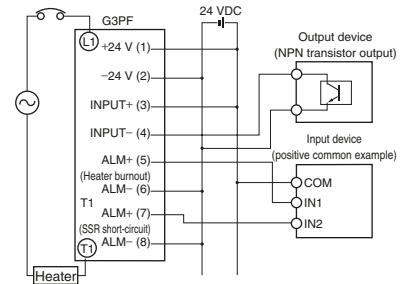

Controlled by PNP Transistor

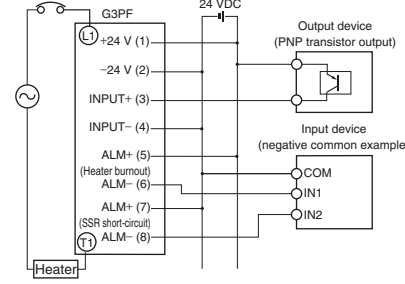

Operation

■ Error Detection Function

● Setting the Heater Burnout Detection Level

- The heater burnout detection level is set with switches on the front of the G3PF.

- Turn the switches to the current value to be detected. The top switch sets the tens digit, and the bottom switch sets the ones digit.

*Example of setting 12 A
 Setting switch (top row): 1
 Setting switch (bottom row): 2



● Operation during an Error

Model	Condition	Alarm indicator (red)	Alarm output	
			Terminals 5-6	Terminals 7-8
G3PF-□□□B	Normal	Unlit	OFF	None
	Heater burnout, SSR open-circuit	Lit	ON	
	SSR short-circuit	Flashing		
G3PF-□□□B-CTB G3PF-□□□B-STB	Normal	Unlit	OFF	OFF
	Heater burnout, SSR open-circuit	Lit	ON	OFF
	SSR short-circuit	Flashing	OFF	ON

● Heater Burnout Detection Function

	G3PF-□25B, G3PF-□25B-□□□	G3PF-□35B, G3PF-□35B-□□□
Detection setting range	1 to 25 A (1-A increments)	1 to 35 A (1-A increments)
Detection tolerance	±5% (±20% for a rated load current setting of 20% or less. See table at right for details.)	
Detection time	1.0 s max. (with ON/OFF control)	

- Note 1.** The alarm is output if the load current falls below the error detection current.
- 2.** Take the detection tolerance into consideration in setting the error detection current. (For details, refer to the *Heater Burnout Detection Current Range* table at the right.)
- 3.** When using cycle control, heater burnout detection is possible at a control cycle of 200 ms min. and an output duty of 50% min. (When combined with the G32A-EA, heater burnout can be detected at an output duty of 50% or higher.)
- 4.** When using cycle control, the detection time increases in inverse proportion to the output duty.
- 5.** When used in combination with optimal cycle control (G3ZA), the heater burnout detection function cannot be used.
- 6.** Do not set the heater burnout detection current to 0 A. Doing so would cause constant detection of a SSR short-circuit failure when no operation input is applied. Also, settings 4 to 9 on the top setting switch are invalid. Do not set the switch to these values.
- 7.** The heater burnout detection function cannot be disabled. If it is not needed, set it to the lowest setting (1 A).
- 8.** When the heater burnout detection level is changed, the new value becomes effective immediately after the change. (The set value can be changed in the G3PF even during operation.)

● SSR Failure Detection

Detection level	One-half the set value for heater burnout detection
Detection time	1.0 sec max. (ON/OFF control) (See note.)

Note: When using cycle control, the detection time increases in inverse proportion to the output duty.

● Heater Burnout Detection Current Range

Setting switch		Heater burnout detection current (A)			
Top switch (tens digit)	Bottom switch (ones digit)	G3PF-□25B, G3PF-□25B-□□□		G3PF-□35B, G3PF-□35B-□□□	
		Minimum	Maximum	Minimum	Maximum
0	0	Cannot be set		Cannot be set	
0	1	0.8	1.2	0.8	1.2
0	2	1.6	2.4	1.6	2.4
0	3	2.4	3.6	2.4	3.6
0	4	3.2	4.8	3.2	4.8
0	5	4.0	6.0	4.0	6.0
0	6	5.7	6.3	4.8	7.2
0	7	6.7	7.4	5.6	8.4
0	8	7.6	8.4	7.6	8.4
0	9	8.6	9.5	8.6	9.5
1	0	9.5	10.5	9.5	10.5
1	1	10.5	11.6	10.5	11.6
1	2	11.4	12.6	11.4	12.6
1	3	12.4	13.7	12.4	13.7
1	4	13.3	14.7	13.3	14.7
1	5	14.3	15.8	14.3	15.8
1	6	15.2	16.8	15.2	16.8
1	7	16.2	17.9	16.2	17.9
1	8	17.1	18.9	17.1	18.9
1	9	18.1	20.0	18.1	20.0
2	0	19.0	21.0	19.0	21.0
2	1	20.0	22.1	20.0	22.1
2	2	20.9	23.1	20.9	23.1
2	3	21.9	24.2	21.9	24.2
2	4	22.8	25.2	22.8	25.2
2	5	23.8	26.3	23.8	26.3
2	6	Cannot be set		24.7	27.3
2	7			25.7	28.4
2	8			26.6	29.4
2	9			27.6	30.5
3	0			28.5	31.5
3	1			29.5	32.6
3	2			30.4	33.6
3	3			31.4	34.7
3	4			32.3	35.7
3	5			33.3	36.8
3	6	Cannot be set			
·	·				
·	·				
9	9				

Nomenclature

■ G3PF-□□□B

● Terminal Arrangement

Terminal name	Terminal number	Screw size
Main circuit terminals (output)	L1, T1	M5
Detection power supply (input)	1, 2	M3
Operation input (input)	3, 4	
Alarm output terminals (output)	5, 6	

● Indicators

Name	Color	Condition	Meaning
Operation indicator	Yellow	Lit	Operating
Alarm indicator	Red	Lit	Heater burnout detection
		Flashing	SSR short-circuit detection

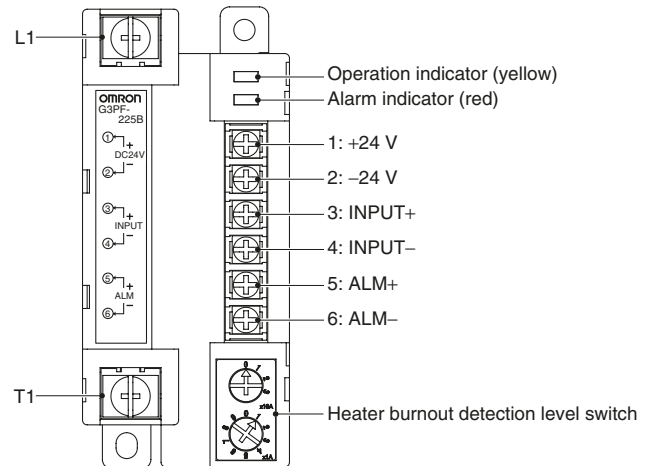

■ G3PF-□□□B-CTB, G3PF-□□□B-STB

● Terminal Arrangement

Terminal name	Terminal number	Screw size	
		G3PF-□□□B-CTB	G3PF-□□□B-STB
Main circuit terminals (output)	L1, T1	M5	M5
Operation input (input)	1, 2	Screwless clamp terminals (FK-MCP1.5/8-STF-3.5, made by Phoenix Contact)	M2 slotted screw terminals (MCVW1.5/8-STF-3.5, made by Phoenix Contact)
Detection power supply (input)	3, 4		
Heater burnout alarm output (output)	5, 6		
SSR short-circuit alarm output (output)	7, 8		

● Indicators

Name	Color	Condition	Meaning
Operation indicator	Yellow	Lit	Operating
Alarm indicator	Red	Lit	Heater burnout detection
		Flashing	SSR short-circuit detection

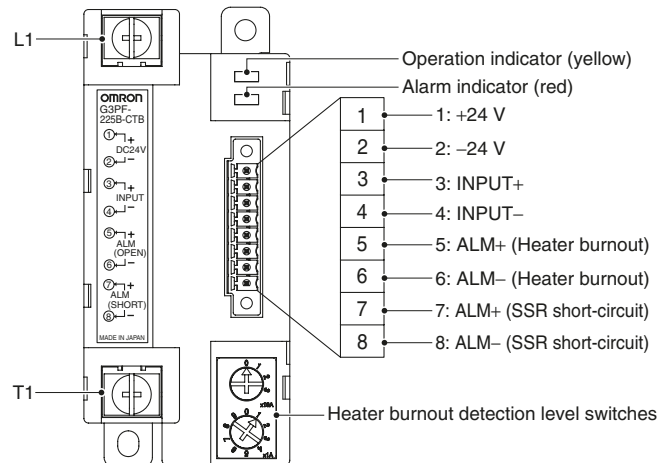

Engineering Data

● Load Current vs. Ambient Temperature

G3PF-□25B

G3PF-□25B-□TB

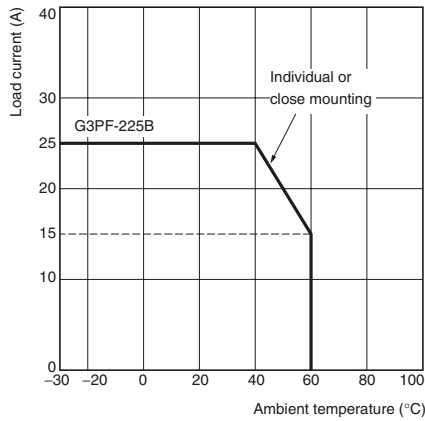

G3PF-□35B

G3PF-□35B-□TB

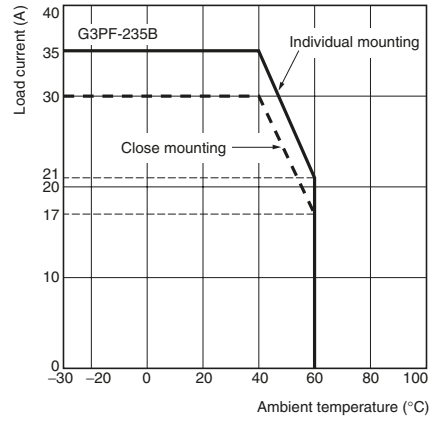

Note: The data above assumes that the Unit is mounted on a vertical surface. If it is mounted on a horizontal surface, reduce the load current shown above by 30%.

● One Cycle Surge Withstand Current

Non-repetitive input (For repetitive input, the figure will be less than the value for surge current withstand indicated by the broken line.)

G3PF-□25B

G3PF-□25B-□TB

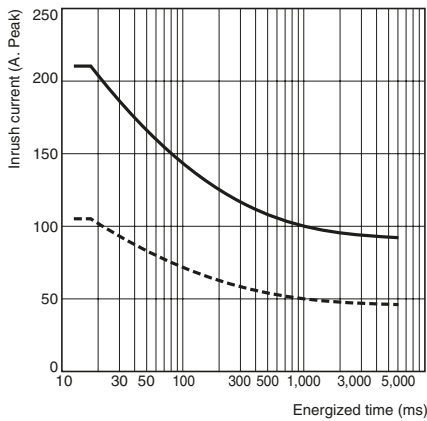

G3PF-□35B

G3PF-□35B-□TB

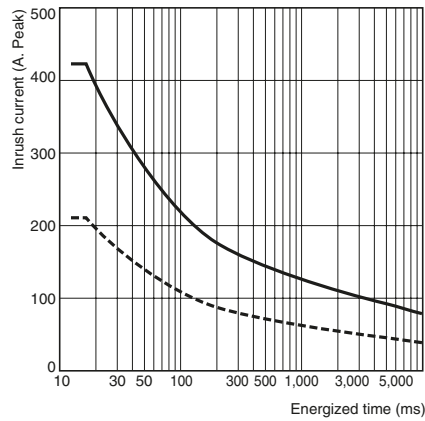

Solid State Relays with Built-in Current Transformer G3PF

Dimensions

(Unit: mm)

Main unit

G3PF-□25B

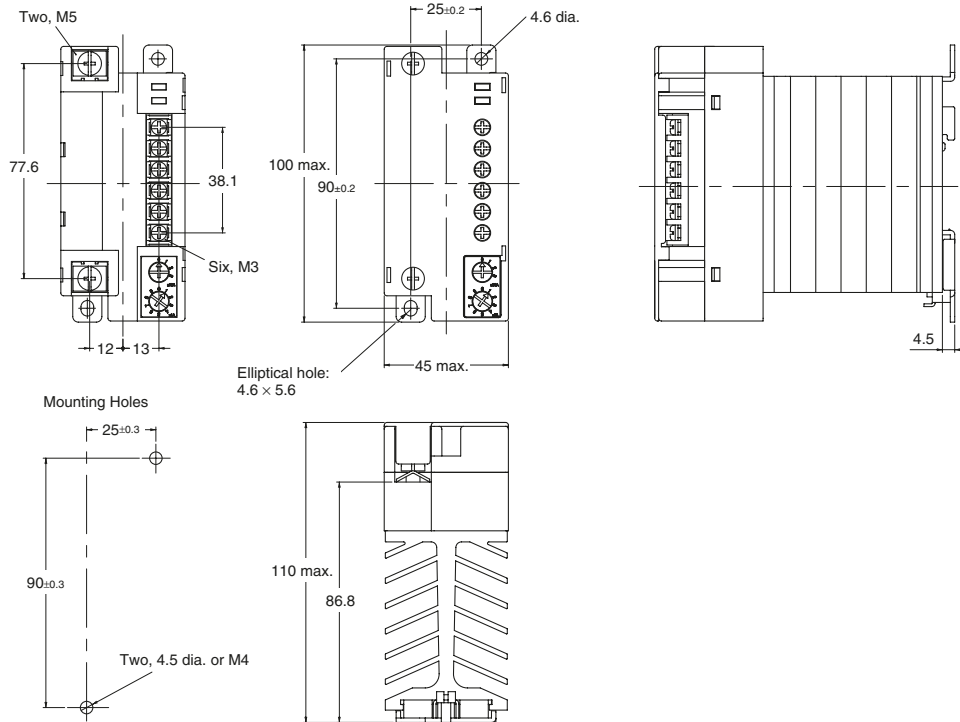

G3PF-□35B

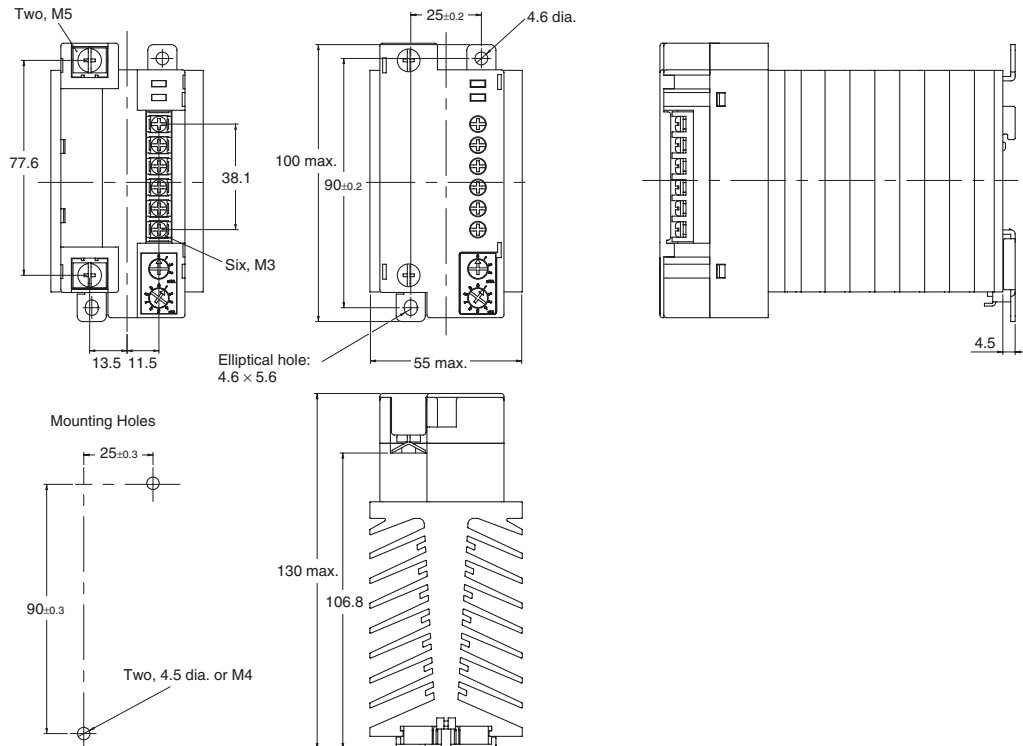

G3PF-□25B-CTB

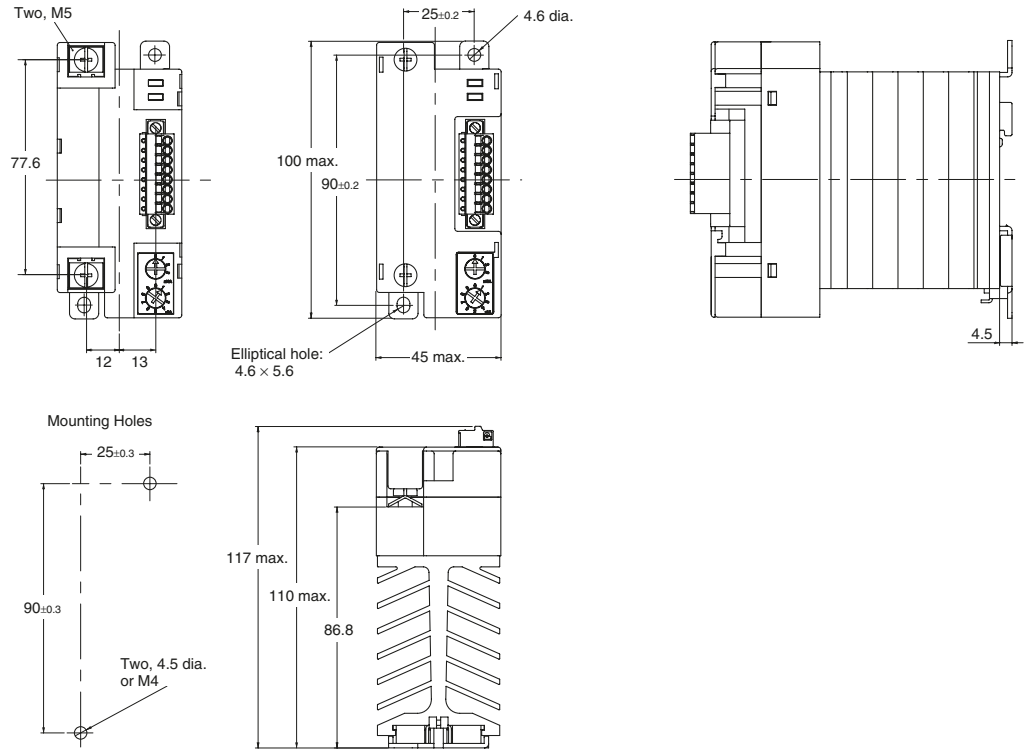

G3PF-□35B-CTB

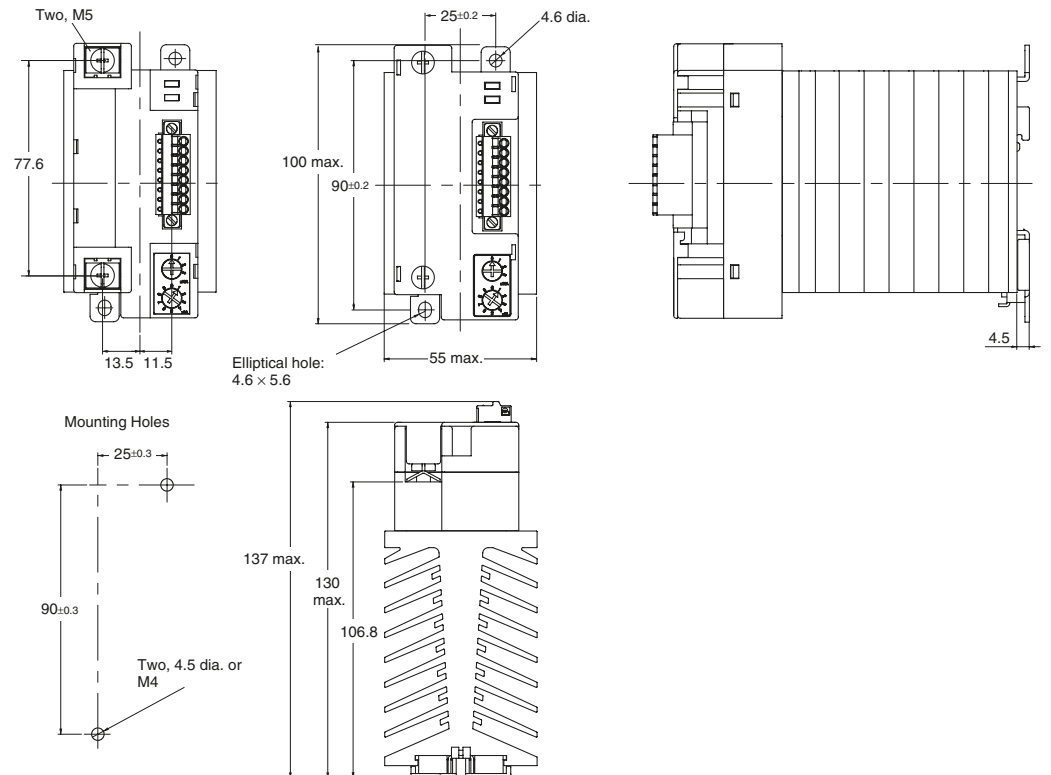

Solid State Relays with Built-in Current Transformer G3PF

G3PF-□25B-STB

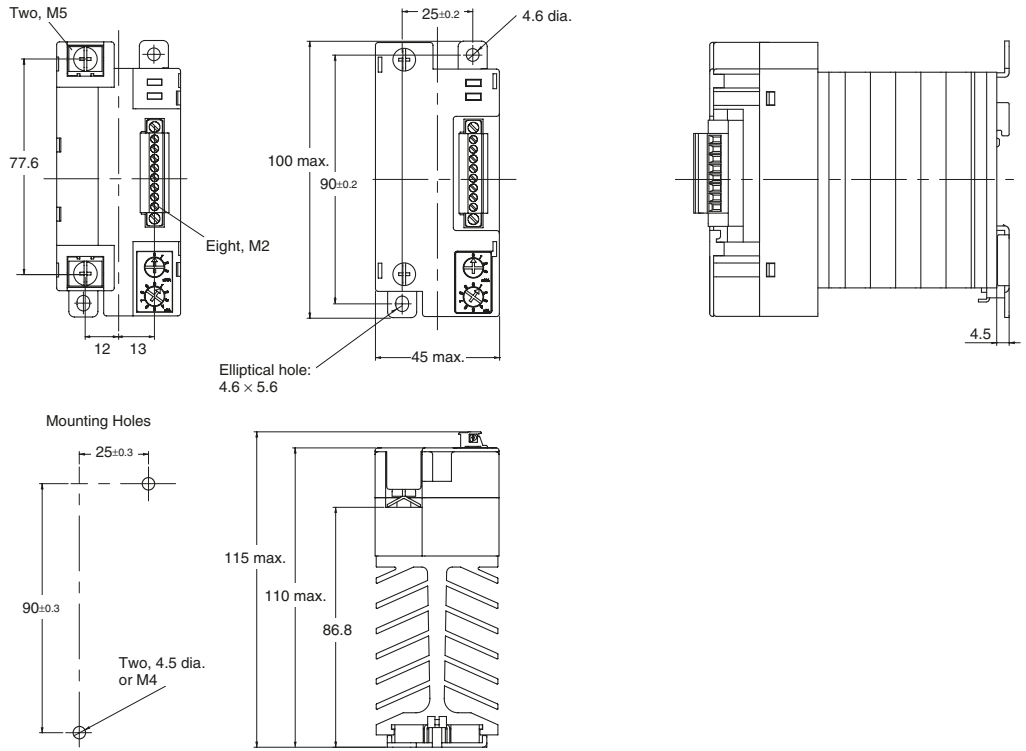

G3PF-□35B-STB

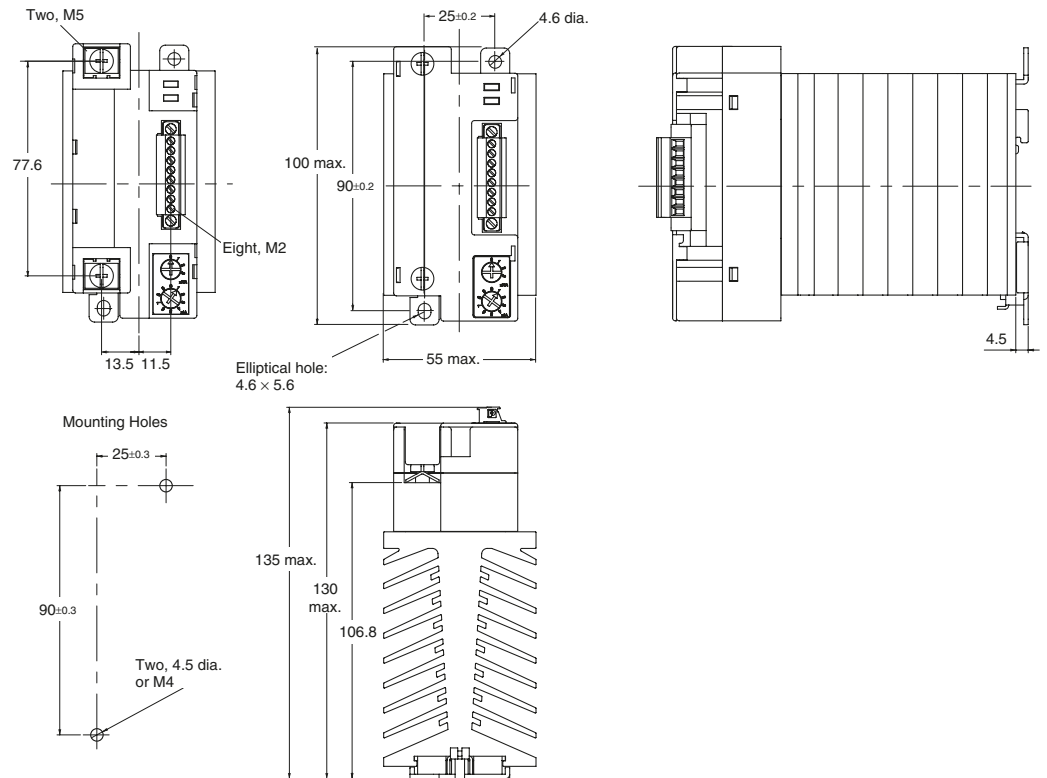

Safety Precautions

CAUTION

The G3PF may rupture if short-circuit current flows. As protection against accidents due to short-circuiting, be sure to install protective devices, such as fuses and no-fuse breakers, on the power supply side.



Minor burns may occasionally occur. Do not touch the SSR or the heat sink while the power is being supplied or immediately after the power supply has been turned OFF. The SSR and heat sink become extremely hot.



Minor electrical shock may occasionally occur. Do not touch the main circuit terminals on the SSR immediately after the power supply has been turned OFF. Shock may result due to the electrical charge stored in the built-in snubber circuit.



Minor electrical shock may occasionally occur. Always turn OFF the power supply before performing wiring. Also, always attach the cover terminal.



Precautions for Safe Use

OMRON constantly strives to improve quality and reliability. SSRs, however, use semiconductors, and semiconductors may commonly malfunction or fail. In particular, it may not be possible to ensure safety if the SSRs are used outside the rated ranges. Therefore, always use the SSRs within the ratings. When using an SSR, always design the system to ensure safety and prevent human accidents, fires, and social harm in the event of SSR failure. System design must include measures such as system redundancy, measures to prevent fires from spreading, and designs to prevent malfunction.

(1) Operating and Storage Environments

Do not use or store the G3PF in the following locations. Doing so may result in damage, malfunction, or deterioration of performance characteristics.

1. Locations subject to corrosive or flammable gases.
2. Do not store in locations subject to ambient storage temperatures outside the range -30 to 70°C .
3. Do not use in locations subject to ambient operating temperatures outside the range -20 to 60°C .
4. Do not use in locations subject to relative humidity outside the range 25% to 85%.
5. Locations subject to high temperature or high humidity.
6. Locations subject to condensation as the result of rapid changes in temperature.
7. Locations subject to exposure to water, oil, or chemicals.
8. Locations subject to dust (especially iron dust) or salts.
9. Locations subject to rainwater or water splashes.
10. Locations subject to direct sunlight.
11. Locations subject to shock or vibration.

(2) Transport

Do not transport the G3PF under the following conditions. Doing so may result in damage, malfunction, or deterioration of performance characteristics.

1. Conditions in which the G3PF may be subject to water or oil splashes.
2. Conditions in which the G3PF may be subject to high temperature or high humidity.
3. Conditions in which the G3PF may be subject to condensation as the result of rapid changes in

temperature.

4. Conditions in which the G3PF may be dropped or subject to excessive vibration or shock.
5. Conditions in which the G3PF is not packaged.

(3) Mounting

1. Do not use the G3PF if the heat radiation fins have been bent by being dropped. Doing so may result in malfunction due to a reduction in the heat radiation performance.
2. Do not block the movement of the air surrounding the SSR or heat sink.
Abnormal heating of the SSR may result in shorting failures of the output elements or burn damage.
3. Make sure that there is no excess ambient temperature rise due to the heat generation of the G3PF. If the G3PF is mounted inside a panel, install a fan so that the interior of the panel is fully ventilated. Otherwise, shorting failures of the output elements or burn damage may result.
4. Make sure the DIN track is securely mounted. Otherwise, the G3PF may fall.
5. Do not handle the G3PF with oily or dusty (especially iron dust) hands. Doing so may result in malfunction.
6. Mount the G3PF in the specified direction (on a vertical or horizontal surface). Otherwise excessive heat generated by the G3PF may cause short-circuit failures of the output elements or burn damage.

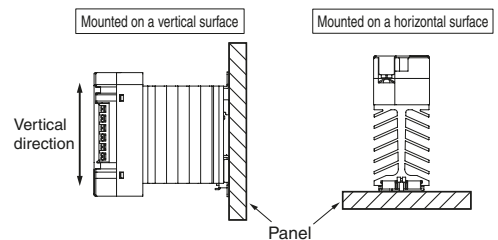

7. When mounting the G3PF to a control panel or other fixture with screws, be sure to tighten the screws to a torque of 0.98 to 1.47 N·m. A lower level of tightening torque may cause the G3PF to fall.
8. Do not drop the G3PF or subject it to excessive vibration or shock. Doing so may result in damage, malfunction, or deterioration of performance characteristics.

(4) Wiring

1. Use wires that are thick enough for the load current. Otherwise, excessive heat generated by the wire may cause burning.

Tightening torque	M2: 0.22 to 0.28 N·m
	M3: 0.4 to 0.56 N·m
	M5: 1.57 to 2.35 N·m
Control connector mounting torque (detachable terminal)	0.25 to 0.3 N·m
2. When tightening terminal screws, prevent any non-conducting material from becoming caught between the screws and the tightening surface. Otherwise, excessive heat generated by the terminal may cause burning.
3. Use wires that are suited to the load current and voltage. Otherwise, excessive heat generated by the wires may cause burning, or the outer covering of the wire may melt, resulting in electrical shock or ground fault.
4. Use a crimp terminal size that is suited to the diameter of the wire. Otherwise, it may result in burning, or the outer covering of the wire may melt, resulting in electrical shock or ground fault.
5. Do not use wires with a damaged outer covering. Otherwise, it may result in electric shock or ground leakage.

6. Do not wire any wiring in the same duct or conduit as power or high-tension lines. Otherwise, inductive noise may damage the G3PF or cause it to malfunction.

(5) Adjustment and Use

Do not adjust or use the G3PF under the following conditions. Doing so may result in damage, malfunction, or burning.

1. Conditions in which voltage or current exceeding the rated values is applied to the input or output terminals.
2. Conditions in which a load exceeding the rated range is selected or used.
3. Conditions in which a power supply frequency other than the rated frequency is selected or used.

(6) Failure Detection

If the G3PF control circuit or alarm output circuit should malfunction, the failure detection function and output will not operate normally. To protect against this possibility, it is recommended that the design includes redundant safety functions.

(7) Noise and Surge Effects

If noise or an electrical surge occurs that exceeds the malfunction withstand limit for the G3PF output circuit, the output will turn ON for a maximum of one half cycle to absorb the noise or surge. Confirm that turning the output ON for a half cycle will not cause a problem for the device or system in which the G3PF is being used prior to actual use. The G3PF malfunction withstand limit is shown below.

- Malfunction withstand limit (reference value): 500 V

Note: This value was measured under the following conditions.

Noise duration: 100 ns and 1 μs
 Repetition period: 100 Hz
 Noise application time: 3 min

Precautions for Correct Use

The SSR in operation may cause an unexpected accident. Therefore it is necessary to test the SSR under the variety of conditions that are possible. As for the characteristics of the SSR, it is necessary to consider differences in characteristics between individual SSRs.

The ratings in this catalog are tested values in a temperature range between 15°C and 30°C, a relative humidity range between 25% and 85%, and an atmospheric pressure range between 88 and 106 kPa. It will be necessary to provide the above conditions as well as the load conditions if the user wants to confirm the ratings of specific SSRs.

(1) Solvents

Do not allow the resin parts of the G3PF to come in contact with solvents, such as alcohol, thinner, trichloroethane, or gasoline. Doing so will dissolve markings and may result in deteriorating the performance of the parts.

(2) Oil

Do not allow the terminal cover of the G3PF to come in contact with oil. Doing so may cause the cover to become cloudy or to crack.

(3) Mounting

Do not drop the G3PF or subject it to excessive vibration. Doing so may result in damage, malfunction, or deterioration of performance characteristics.

(4) Mounting Interval (Panel Mounting)

Note: When close mounting, check *Load Current vs. Ambient Temperature* under *Engineering Data*.

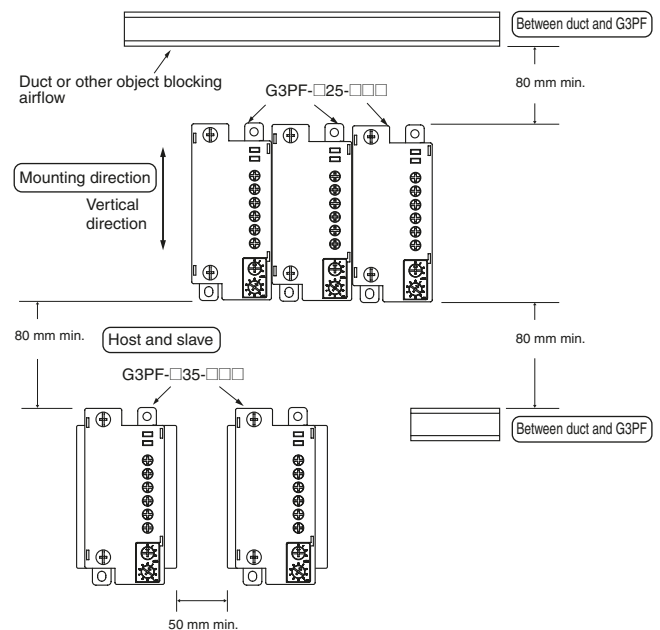

(5) G3PF and Duct (or Other Object Blocking Airflow) Relationship

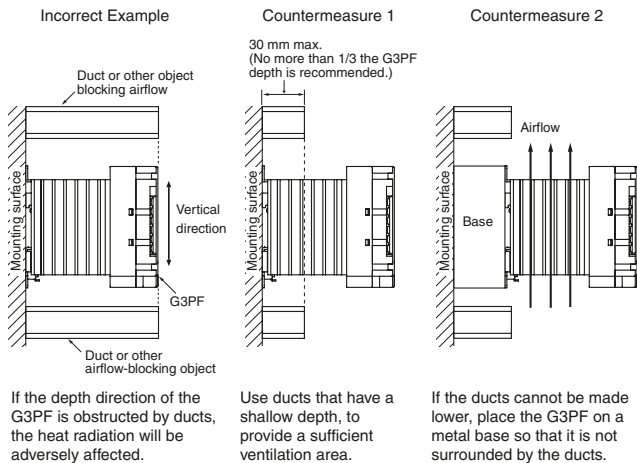

(6) Ventilation Outside the Control Panel

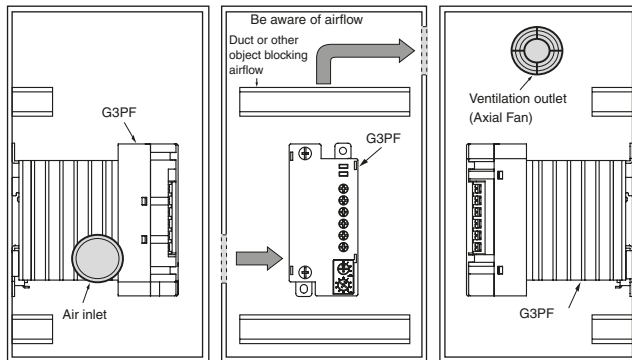

- Note 1.** If the air inlet or air outlet has a filter, clean the filter regularly to prevent it from clogging to ensure an efficient flow of air.
- Do not locate any objects around the air inlet or air outlet, otherwise the objects may obstruct the proper ventilation of the control panel.
 - A heat exchanger, if used, should be located in front of the G3PF to ensure the efficiency of the heat exchanger.

(7) G3PF Ambient Temperature

The rated current of the G3PF is measured at an ambient temperature of 40°C.

- (8) The G3PF uses a semiconductor to switch the load. This causes the temperature inside the control panel to increase due to heating resulting from the flow of electrical current through the load. G3PF reliability can be increased by adding a ventilation fan to the control panel to dispel this heat, thus lowering the ambient temperature of the G3PF.
(Arrhenius's law suggests that life expectancy is doubled by each 10°C reduction in ambient temperature.)

G3PF rated current (A)	25 A	35 A
Required number of fans per G3PF	0.4	0.54

Example: For 10 G3PF SSRs with load currents of 35 A,
 $0.54 \times 10 = 5.40$

Thus, 6 fans would be required.

- Note 1.** Size of fans: 92 mm², Air volume: 0.7 m³/min, Ambient temperature of control panel: 30°C
- If there are other instruments that generate heat in the control panel in addition to SSRs, more ventilation will be required.
 - Ambient temperature: The temperature that will allow the SSR to cool by convection or other means.

Warranty and Application Considerations

Read and Understand this Catalog

Please read and understand this catalog before purchasing the products. Please consult your OMRON representative if you have any questions or comments.

Warranty and Limitations of Liability

WARRANTY

OMRON's exclusive warranty is that the products are free from defects in materials and workmanship for a period of one year (or other period if specified) from date of sale by OMRON.

OMRON MAKES NO WARRANTY OR REPRESENTATION, EXPRESS OR IMPLIED, REGARDING NON-INFRINGEMENT, MERCHANTABILITY, OR FITNESS FOR PARTICULAR PURPOSE OF THE PRODUCTS. ANY BUYER OR USER ACKNOWLEDGES THAT THE BUYER OR USER ALONE HAS DETERMINED THAT THE PRODUCTS WILL SUITABLY MEET THE REQUIREMENTS OF THEIR INTENDED USE. OMRON DISCLAIMS ALL OTHER WARRANTIES, EXPRESS OR IMPLIED.

LIMITATIONS OF LIABILITY

OMRON SHALL NOT BE RESPONSIBLE FOR SPECIAL, INDIRECT, OR CONSEQUENTIAL DAMAGES, LOSS OF PROFITS, OR COMMERCIAL LOSS IN ANY WAY CONNECTED WITH THE PRODUCTS, WHETHER SUCH CLAIM IS BASED ON CONTRACT, WARRANTY, NEGLIGENCE, OR STRICT LIABILITY.

In no event shall the responsibility of OMRON for any act exceed the individual price of the product on which liability is asserted.

IN NO EVENT SHALL OMRON BE RESPONSIBLE FOR WARRANTY, REPAIR, OR OTHER CLAIMS REGARDING THE PRODUCTS UNLESS OMRON'S ANALYSIS CONFIRMS THAT THE PRODUCTS WERE PROPERLY HANDLED, STORED, INSTALLED, AND MAINTAINED AND NOT SUBJECT TO CONTAMINATION, ABUSE, MISUSE, OR INAPPROPRIATE MODIFICATION OR REPAIR.

Application Considerations

SUITABILITY FOR USE

OMRON shall not be responsible for conformity with any standards, codes, or regulations that apply to the combination of products in the customer's application or use of the products.

Take all necessary steps to determine the suitability of the product for the systems, machines, and equipment with which it will be used.

Know and observe all prohibitions of use applicable to this product.

NEVER USE THE PRODUCTS FOR AN APPLICATION INVOLVING SERIOUS RISK TO LIFE OR PROPERTY WITHOUT ENSURING THAT THE SYSTEM AS A WHOLE HAS BEEN DESIGNED TO ADDRESS THE RISKS, AND THAT THE OMRON PRODUCTS ARE PROPERLY RATED AND INSTALLED FOR THE INTENDED USE WITHIN THE OVERALL EQUIPMENT OR SYSTEM.

Disclaimers

PERFORMANCE DATA

Performance data given in this catalog is provided as a guide for the user in determining suitability and does not constitute a warranty. It may represent the result of OMRON's test conditions, and the users must correlate it to actual application requirements. Actual performance is subject to the OMRON Warranty and Limitations of Liability.

CHANGE IN SPECIFICATIONS

Product specifications and accessories may be changed at any time based on improvements and other reasons. Consult with your OMRON representative at any time to confirm actual specifications of purchased product.

DIMENSIONS AND WEIGHTS

Dimensions and weights are nominal and are not to be used for manufacturing purposes, even when tolerances are shown.

CONSULTING DISTRIBUTOR



POHL

POHL Electronic GmbH
Eduard-Maurer-Straße 11a • 16761 Hennigsdorf
Tel. +49 3302 81893-0 • Fax +49 3302 81893-99
www.pohl-electronic.de • info@pohl-electronic.de

ALL DIMENSIONS SHOWN ARE IN MILLIMETERS.

To convert millimeters into inches, multiply by 0.03937. To convert grams into ounces, multiply by 0.03527.

OMRON Corporation
Industrial Automation Company
Control Devices Division H.Q.
Shiokoji Horikawa, Shimogyo-ku,
Kyoto, 600-8530 Japan
Tel: (81) 75-344-7109/Fax: (81) 75-344-7149

Regional Headquarters
OMRON EUROPE B.V.
Wegalaan 67-69, NL-2132 JD Hoofddorp
The Netherlands
Tel: (31)2356-81-300/Fax: (31)2356-81-388

OMRON ELECTRONICS LLC
One Commerce Drive Schaumburg,
IL 60173-5302 U.S.A.
Tel: (1) 847-843-7900/Fax: (1) 847-843-7787

OMRON ASIA PACIFIC PTE. LTD.
No. 438A Alexandra Road # 05-05/08 (Lobby 2),
Alexandra Technopark, Singapore 119967
Tel: (65) 6835-3011/Fax: (65) 6835-2711

OMRON (CHINA) CO., LTD.
Room 2211, Bank of China Tower,
200 Yin Cheng Zhong Road,
Pu Dong New Area, Shanghai, 200120, China
Tel: (86) 21-5037-2222/Fax: (86) 21-5037-2200

Authorized Distributor:

In the interest of product improvement,
specifications are subject to change without notice.

Cat. No. J169-E1-01

0607