



INDIVIDUAL DATA SHEETS

LC-P1228P/AP

FOR STANDBY POWER SUPPLIES.
 EXPECTED TRICKLE DESIGN LIFE: 10 – 12 YEARS AT 20°C
 ACCORDING TO EUROBAT.

DIMENSIONS (MM)



Terminal type (option)

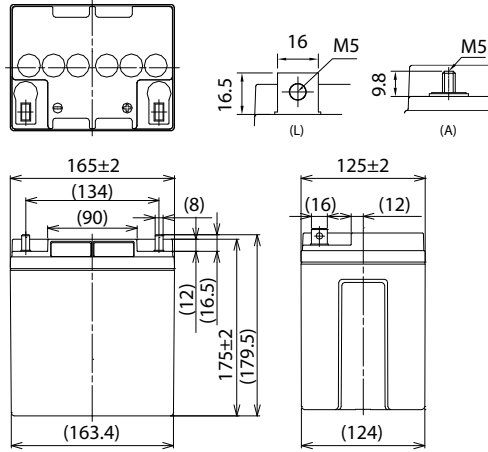

Contents indicated (including the recycle marking, etc.) are subject to change without notice. Battery case resin: flame-retardant (UL94 V-0)

Specifications		LC-P1228P/AP
Nominal voltage (V)		12
Nominal capacity	20 hours rate (Ah)	28.0
Dimensions	Length (mm)	125
	Width (mm)	165
	Total height (mm)	179.5/175
Approx. mass (kg)		9.40
Terminal type	M5 bolt/nut & threaded post	
Capacity (25°C)	20 hours rate (Ah)	28.0
	10 hours rate (Ah)	26.0
	3 hours rate (Ah)	22.0
	1 hour rate (Ah)	21.0
Impedance (mΩ)	Fully charged battery (25°C)	11
Temperature dependency of capacity (%) – 20 hours rate	40°C	102
	25°C	100
	0°C	85
	-15°C	65
Remaining capacity (25°C)	After 3 months (%)	91
	After 6 months (%)	82
	After 12 months (%)	64

DURATION OF DISCHARGE VS. DISCHARGE CURRENT

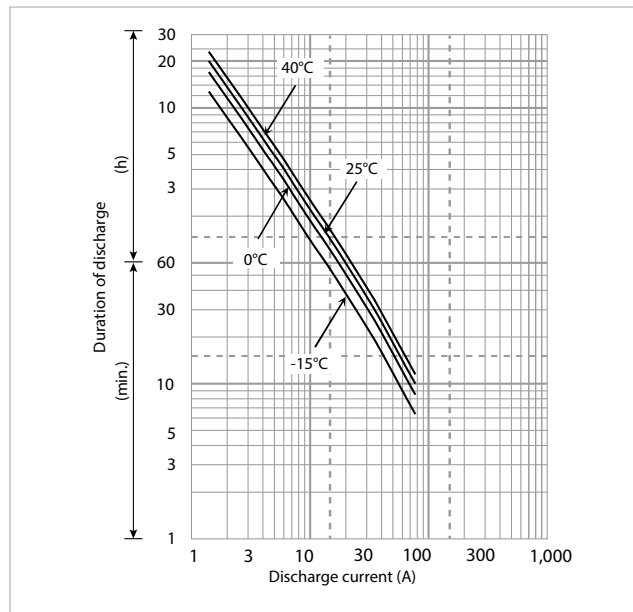

WATT TABLE (25°C)

(Wattage/battery)

Cut-off	5min.	10min.	15min.	20min.	30min.	45min.	1h	1.5h	2h	3h	4h	5h	6h	10h	20h
9.6V	1,160	865	664	585	410	304	260	159	129	91.6	74.1	61.1	50.8	31.8	16.8
9.9V	1,093	849	654	579	404	294	254	156	128	90.4	72.9	60.8	50.4	31.8	16.8
10.2V	1,026	818	643	567	397	288	251	155	127	89.3	71.7	60.5	49.9	31.8	16.8
10.5V	976	784	621	545	386	282	247	154	126	88.1	71.1	60.2	49.5	31.8	16.8
10.8V	903	773	610	539	374	255	218	149	118	84.5	70.5	59.9	49.0	31.8	16.8

AMPERE TABLE (25°C)

(Ampere/battery)

Cut-off	5min.	10min.	15min.	20min.	30min.	45min.	1h	1.5h	2h	3h	4h	5h	6h	10h	20h
9.6V	104	77.2	57.7	50.4	35.0	25.9	22.1	13.5	10.9	7.70	6.20	5.10	4.30	2.60	1.40
9.9V	98.0	75.8	56.9	49.9	34.5	25.0	21.6	13.2	10.8	7.60	6.10	5.06	4.28	2.60	1.40
10.2V	92.0	73.0	55.9	48.9	33.9	24.5	21.3	13.1	10.7	7.50	6.00	5.03	4.25	2.60	1.40
10.5V	87.5	70.0	54.0	47.0	33.0	24.0	21.0	13.0	10.6	7.40	5.95	4.99	4.23	2.60	1.40
10.8V	81.0	69.0	53.0	46.5	32.0	21.7	18.5	12.6	10.0	7.10	5.90	4.95	4.20	2.60	1.40

All mentioned values are average values



LC-P1228P/AP

CHARGING METHOD (25°C)

Cycle use	Control voltage: 13.6V - 13.8V Initial current: 4.20A or smaller
-----------	---

CUT-OFF VOLTAGE

Discharge current	1.40A - 5.60A	5.60A - 14.0A	14.0A - 28.0A	28.0A - 56.0A	56.0A - 84A
Cut-off voltage	10.5V	10.2V	9.9V	9.3V	8.7V

INFLUENCE OF TEMPERATURE ON TRICKLE LIFE

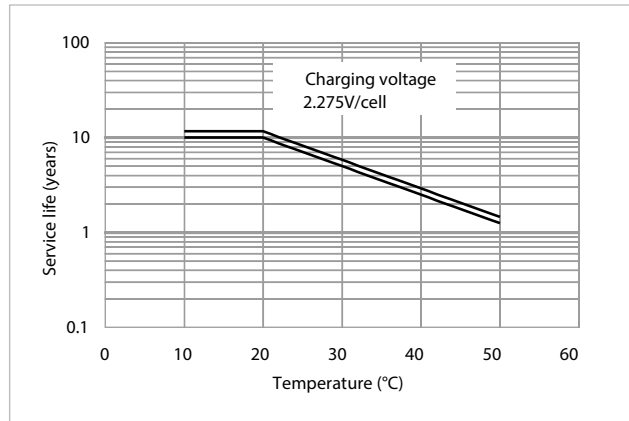

RESIDUAL CAPACITY TEST RESULT

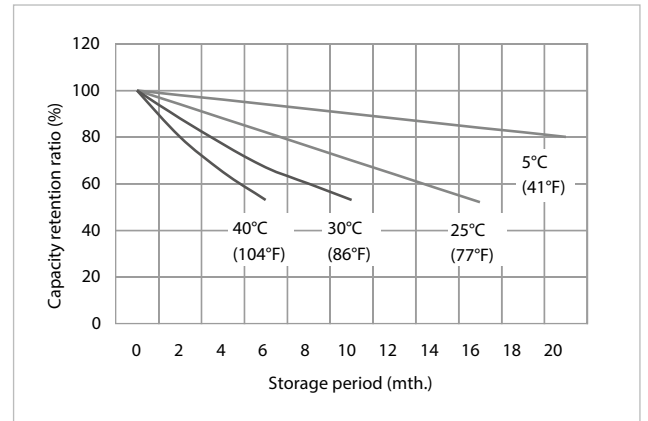

CONSTANT-VOLTAGE CONSTANT-CURRENT CHARGE CHARACTERISTICS FOR TRICKLE USE

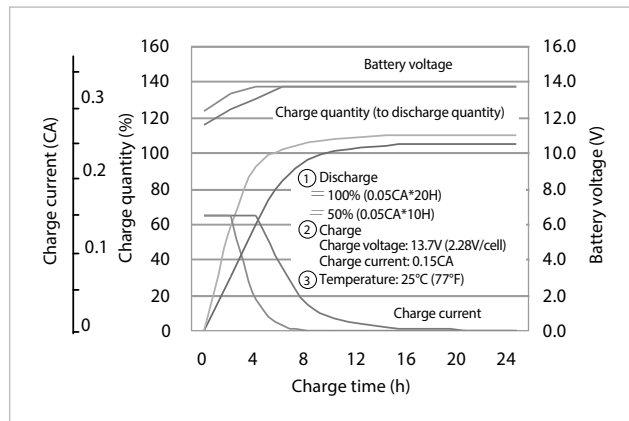

DISCHARGE CAPACITY BY TEMPERATURE AND BY DISCHARGE CURRENT

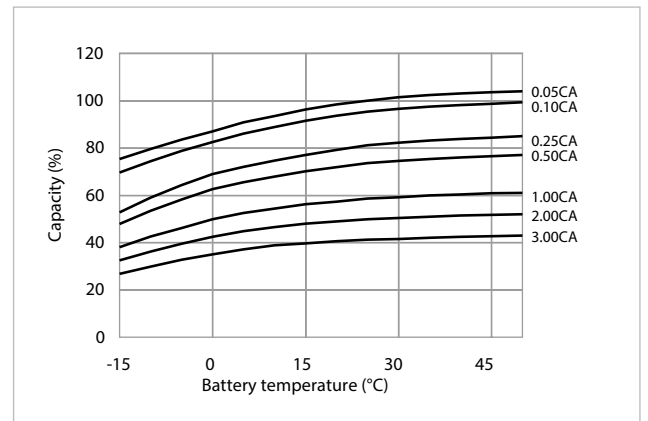

DISCHARGE CHARACTERISTICS

